

Leaving Certificate Engineering

A guide to the
Engineering - Technology Project: Design



Contents

Foreword	2
Design Brief	3
Analysis of the brief	7
Investigation of possible solutions	11
Criteria for selection of solution	16
Planning & Production Drawings	17
Manufacture	22
Testing & Evaluation	26

Published by:

PDST Professional Development Service for Teachers
T4 – Technology Subjects Support Service
Galway Education Centre
Cluain Mhuire
Wellpark
Galway
Email: admin@t4.ie
Web: www.t4.ie and www.pdst.ie

Copyright © PDST Professional Development Service for Teachers 2012.

Permission granted to reproduce for educational use providing the source is acknowledged. Copying for any other purposes prohibited without the prior written permission of the publisher.

Foreword

Leaving Certificate Engineering affords students the opportunity to develop skills in creativity, problem solving, innovation, research, enterprise, design, manufacture and reflection. ICT is an integral part of this learning environment. The student project provides the medium through which some or all of these skills may be expressed and assessed. 25% (150 marks) of the total marks in Engineering, at this level, are allocated to the production of the student project.

As part of the Engineering – Technology Project: Design the student must produce an artefact as a solution to a given brief accompanied by a folio which will clearly exhibit the students thought process as they work through the development of their solution; *“the folio provides a record of the work of the candidate and should contain all the details of the project work from the initial ideas to the final evaluation”*. (Chief Examiners Report: State Examination Commission, 2011). For this reason, it is vital that the folio is compiled as the process develops. Each stage of the process informs the next and the folio serves as a means of capturing this information. The breakdown of marks for each aspect of the project is detailed below;

Artefact	-	110 Marks
Folio	-	40 Marks

Whilst there are 40 marks (6.66%) available for the production of the folio, it must be appreciated that the quality of the process of design, which is captured in the folio, will have a significant impact on the quality of the artefact for which there are 110 marks (18.33%) awarded.

The ability on the part of the student to communicate the thought process throughout the production of the project is of utmost importance. It is essential that this thought process is evident to any person that reads, or indeed assesses, the folio. Annotations, sketches, questions and conclusions on each section of the project will allow the student to communicate their thoughts distinctly to the reader. Therefore, it is critical that the process of reflection become an everyday activity in the Engineering classroom.

The design brief issues from the State Examinations Commission in October, of year two, of the Leaving Certificate Course. A specified deadline for completion is indicated in the instructions to candidates. The purpose of this document is to offer guidance to both teachers and students on possible approaches to successfully completing the Engineering Project.

Design Brief

The Engineering design brief outlines a problem, for which the students are required to produce a solution. The solution to this problem results in the production of an artefact. The process through which the students set about solving the associated problems is documented in a written folio.

The design brief is presented in the following fashion.

Introductory paragraph/preamble

This sets a context for the given brief. The preamble will contain information which will guide the student in the analysis and understanding of the design problem.

Design statement

This is a clear statement which outlines the problem posed.

Design specifications, constraints and limitations:

These outline the constraints or limitations placed on the design e.g. maximum size, voltage etc.

The example outlined below is the *Higher Level Engineering - Project: Design Brief 2012*

Design Brief

1. Introduction

Space travel has been one of the most exciting challenges to scientific discovery and technological innovation in recent history. Once safe, manned, space travel had been achieved the focus then centred on moon landing. Central to exploration of the moon was the design and construction of the Lunar Roving Vehicle (LRV) which could be operated by the astronaut. Two of the key considerations in the design of the vehicle were weight and mobility. The desired mobility was achieved through individual wheel motors. Three consecutive models of LRV were deployed on the moon during the Apollo 15, 16 and 17 missions and at present the Chinese space programme also includes the construction and testing of a new LRV for future journeys of scientific discovery.

Design a model of a Lunar Roving Vehicle (LRV) to the general specifications outlined below.

The LRV should:

- (a) Have propulsion units to provide individual drives for both front wheels;
- (b) Incorporate a central switching console to operate the front wheels;
- (c) Include a steering mechanism for the front wheels;
- (d) Have seating capacity for the driver only.

Presentation of the completed project should ensure that:

- (a) All main operating features are clearly visible without dismantling.
- (b) The longest dimension of the model does not exceed 350 mm.
- (c) Electric power does not exceed 9 volts.

Design Process:

This document outlines the stages the student must work through in order to successfully complete the Engineering Design Project (Higher Level), which is recorded in the written folio.

The process headings are as follows:

	<i>Marks Awarded</i>
• Analysis of the given brief	5
• Investigation of possible solutions	10
• Criteria for selection of your own individual solution	5
• Production drawings/plans	10
• Testing and Evaluation	5
• Presentation of the Folio	5

Each of these headings will be dealt with individually, in turn, through this document. Presentation is central to all elements of the folio and hence will be addressed first.

Presentation of the completed folio

The folio represents a record of the work of the candidate from the initial ideas to the final evaluation. As such, it should be well presented and capture the interest of the reader. Individual approaches are encouraged including photographs, sketches, handwritten notes or typed details. Freehand sketches and hand-written annotations should be used to enhance and personalise the presentation. Notes and explanations can be inserted wherever it is deemed necessary.

The following points should be considered by the student;

- The presentation, in whatever format is chosen, A3 or A4, must tell its own story. Sketches, annotations, digital photos, images from magazines, books, newspapers and the internet may be employed.
- Virtually any conceivable method of presentation can be used to convey the thought process.
- Try to be as creative and unique as possible.
- Any prior knowledge in the use of word processing/desktop publishing software should be used.
- Experiment with various types of print paper other than standard cartridge paper.
 - Heavy gauge cartridge paper
 - Coloured paper
 - Watercolour paper
 - Coated paper / Photographic paper / Trace paper

- Layout should be kept clear. It should be easy to follow but unique to the student’s creative ability. It should have a logical format and show evidence of good research.
- The presentation of the document could be enhanced with a well-designed front page, detailing the student’s examination number, and could incorporate some graphic design which reflects what is detailed within the folio.
- The completed folio should be suitably presented for the reader. As part of the presentation a method of binding the folio should be considered.

Work Plan.

A work plan will facilitate students to make the best use of the time available to ensure that the project is completed within the time constraints. A work plan will enable goals to be set for each week of the project and break down the project into achievable bite sizes. This will help to ensure that time is used effectively and reduce the need for excessive work as the deadline for completing the project approaches. A copy of the school calendar can be used to identify holidays, school trips, dates for pre-exams etc. which will help to plan the time available more effectively and accurately.

The work plan is best presented in graphical format. A number of possible approaches, taken by students, are presented below and overleaf.

Timeline for completion of LC Engineering Project

	Oct.		November			December			January				February				March						
	17	25	1	8	15	22	29	6	13	20	27	3	10	17	24	31	7	14	21	28	7	14	
	PROGRESS INDICATOR		PROGRESS INDICATOR			PROGRESS INDICATOR			PROGRESS INDICATOR				PROGRESS INDICATOR				PROGRESS INDICATOR						
Project Analysis																							
Investigation																							
Mid-Term Break - Investigation																							
Development of Ideas - Modelling																							
Development of Ideas - Modelling																							
Production of Drawings & Parts List																							
Commence Manufacture																							
Manufacture																							
Manufacture																							
Christmas Holidays																							
Manufacture																							
Manufacture																							
Manufacture																							
Manufacture																							
Pre - Leaving Cert. Exams																							
Pre - Leaving Cert. Exams																							
Mid Term Break																							
Manufacture & Completion of Assembly																							
Testing & Evaluation - Folio Completed																							

Week No.	WEEK NUMBER						
	WK. 1	WK. 2	WK. 3	WK. 4	WK. 5	WK. 6	WK. 7
Work							
Analysis							
Investigation							
Investigation - Ideas							
Prototyping							
Working Drawings							
Manufacture							
Assembly							
Wiring							
Testing & Evaluation							
	Mid Term Break						
	Christmas Holidays						
	Pre-Leaving Cert. Exams						
	WK. 18	WK. 19	WK. 20	WK. 21	WK. 22	WK. 23	WK. 24

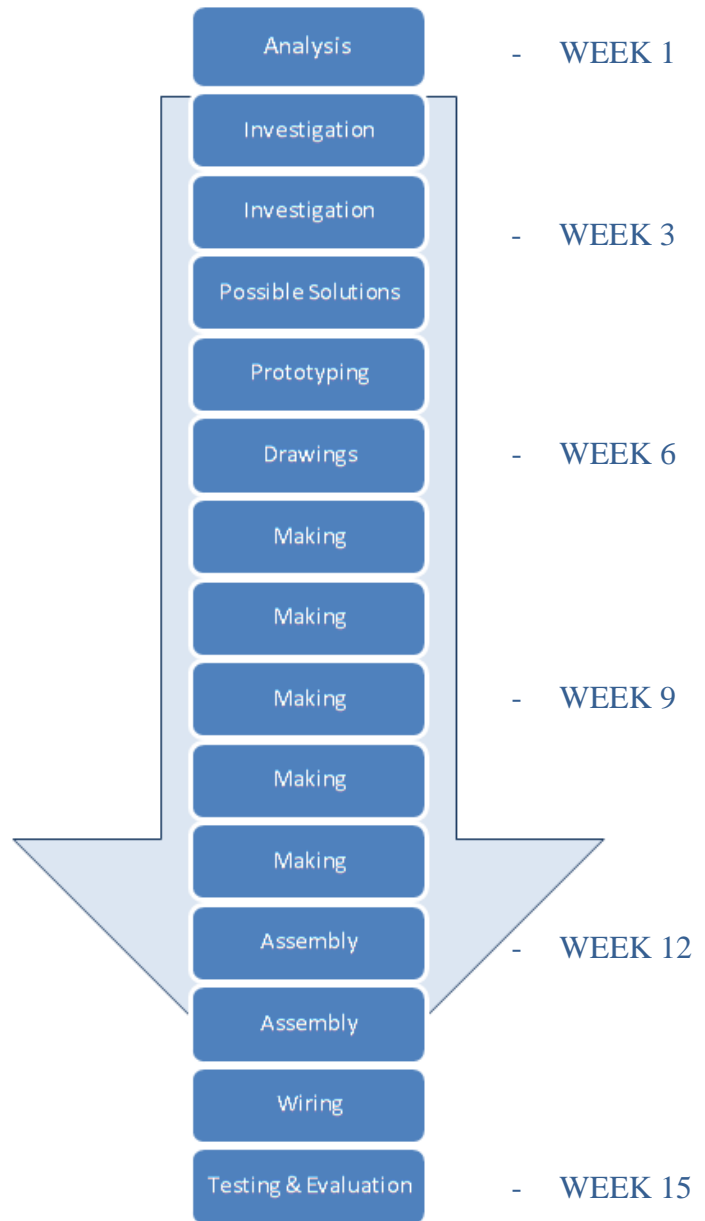

Where do I start?

You should start with the analysis of the brief and work through the various stages toward the completion of the process. It is important to note that the process of design is cyclical in nature, and progression through each stage of the process may uncover areas which were not previously considered. This in turn may warrant a revision of previous stages of the process.

Analysis of the brief:

Having read the brief a number of times the next stage is to gain a full understanding of what you are being asked to do. At this stage it is very important that the brief is thoroughly analysed as it serves to inform you of the requirements and constraints of the brief. Performing a poor analysis may lead to overlooking a crucial requisite and hence producing an artefact which doesn't completely satisfy the brief. Having performed a good analysis of the brief you should have clarity on what the brief sets out to achieve and have a clear route towards further investigation.

Explore the brief carefully. A very useful class group exercise at this stage is **brainstorming**. Through group discussion, this exercise serves as vital preparatory work for identifying the direction you may wish to go with your own individual project.



Brainstorming is a group creativity technique designed to generate a large number of ideas for the solution to a problem. Exploring a brief is essentially a brainstorming process. All good design companies start with this exercise. Remember:

- Focus on quantity.
- No criticism is allowed.
- Unusual ideas are welcome.
- There are no wrong answers at this stage.
- Combine and improve ideas.

The teacher takes a passive role but facilitates and guides the situation as necessary.

Analysis of the brief can be facilitated by highlighting the keywords and phrases, expanding on these and outlining your interpretation of them. This section should show evidence of understanding of the given brief. Areas which require solutions should be identified and problems which will be encountered should be recognised. It must be more than just the brief rewritten in your own words. Evaluate all information known about the design situation posed and identify areas which will require further research. Scrutinising the brief in this way will help to direct you along the necessary research paths.

Steps in analysing the brief:

- Highlighting keywords and phrases can help to isolate elements and break down the design situation one step at a time.
- From your own experience what do you know about any of the keywords?
- Keep adding more and more suggestions to the diagram.
- After all possibilities as a group have been exhausted, each student should capture the discussion in a personalised ‘mindmap’ or ‘spider diagram’.
- Evaluate all information known about the design situation posed and identify areas which will require further research. In this way scrutinising the brief will direct you along the necessary research paths.
- A guest speaker, with good knowledge and experience in the area under investigation, may be invited to speak to the group in relation to various aspects which may be overlooked in the brainstorming session.
- It may take a number of attempts before something resembling the following two pages is produced.

DESIGN BRIEF

(2012 ENGINEERING – TECHNOLOGY PROJECT: DESIGN)

Introduction

Space travel has been one of the most exciting challenges to scientific discovery and technological innovation in recent history. Once safe, manned, space travel had been achieved the focus then centred on moon landing. Central to exploration of the moon was the design and construction of the Lunar Roving Vehicle (LRV) which could be operated by the astronaut. Two of the key considerations in the design of the vehicle were weight and mobility. The desired mobility was achieved through individual wheel motors. Three consecutive models of LRV were deployed on the moon during the Apollo 15, 16 and 17 missions and at present the Chinese space programme also includes the construction and testing of a new LRV for future journeys of scientific discovery.

Design a model of a Lunar Roving Vehicle (LRV) to the general specifications outlined below.

The LRV should:

- (a) Have propulsion units to provide individual drives for both front wheels;
- (b) Incorporate a central switching console to operate the front wheels;
- (c) Include a steering mechanism for the front wheels;
- (d) Have seating capacity for the driver only.

Presentation of the completed project should ensure that:

- (a) All main operating features are clearly visible without dismantling.
- (b) The longest dimension of the model does not exceed 350 mm.
- (c) Electric power does not exceed 9 volts.

Brief Analysis



Design and Construction: NASA in collaboration with Boeing and General Motors built and designed the Lunar Rovers that were used on the Apollo missions.

Operated by the Astronaut: Must have a seat and a way of controlling the vehicle that the astronaut can use while in the space suit.

Weight: It must be light enough to be brought to the moon on a rocket but heavy enough so that on the moon where the gravity is 1/6th that of on Earths it does not float away. The materials I can use to make this model do not have to be the final choice for a full scale vehicle but they can be similar to represent the final product.

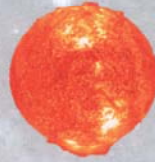

Individual Wheel Motors: Power must be supplied to each wheel and can be controlled individually. Each motor must move with the wheel on the steering mechanism because otherwise it would become disengaged from the wheel.

Apollo 15/16/17: Previous moon missions that brought a lunar rover to the moon. These lunar rovers were the first ever deployed. They were used to travel further on the moon. They carried equipment for the astronauts and had room for them to take samples with them.

Chinese Space Program: The Chinese are working on a lunar rover of their own that may have alternative solutions to problems that the Americans faced.

Future Journeys: In the future further missions may be carried out and a mobile housing or faster vehicles will be needed. I can design a vehicle that may encounter harsher conditions than that on the moon. It may need to be self sufficient and a cabin for housing over long trips will keep the astronauts safe and they

Seating capacity: Only 1 seat needed, garden chairs were used in previous Apollo missions. The seat has to accommodate an astronaut in full gear. The seat isn't a major part of the design but it needs to be taken into consideration with the uses of the rover.

Steering Mechanism: A way of steering both front wheels manual or mechanical. Each wheel is housed on a separate axle and has its own motor. The steering mechanism must move all these components together without disengaging the motor from the wheel the most common method in cars is a rack and pinion system or a worm gear system. Other options include making the vehicle have an articulated steering system or for sharper turns have 4 wheel steering.

Safe, Manned Space Travel: The rover must be safe for the astronaut to use. It must have a low enough center of gravity to not flip over while climbing over an incline, but it also must be high enough to not get caught on rocks. An adjustable ride height can be used to overcome these problems or stabilizers on either side of the vehicle to stop it rolling. Protecting the astronaut is paramount. The vehicle cannot fail or break down while on the moon. If rolling or the vehicle breaks done the car must be able to provide life support for the astronaut or have a way of getting its self out of a problem i.e. using a winch to pull itself out of a crater.

Moon Landing: It must be able to travel to the moon on a rocket and be assembled or readymade when arrived. The forces of space travel must not damage the vehicle. This relates to the size of the body, with a large body it may have to be carried on the exterior of the lunar module in a number of pieces or some assembly may be required. A smaller body allows the vehicle to be carried in one piece and quickly brought into use.

Mobility: Able to navigate the lunar surface. The surface of the moon is covered in craters and mountains. My model must represent a vehicle that would be able to travel around the moon and safely traverse these obstacles. The suspension must be able to handle the rocks while keeping the rover upright. The speed must be controllable and also direction i.e. forward/reverse and steering.

Individual Drive for both Wheels: Both front wheels must have a separate drive system. This means there must be two axels and motors, one for each wheel. The system must incorporate the motors because otherwise they will disengage. It must be able to drive each wheel on its own by using a separate controlling system.

Central Switching Console: A method of controlling the motors and steering either incorporated into the vehicle or in a hand held remote control. The control will have to be able to change the polarity of the motors so the rover can go in reverse and it must also have a way of varying the speed of the rover by using a variable resistor or potentiometer. The controller may be hand held because it's a model, whereas on the finished product they would be incorporated in the vehicle.



Investigation of possible solutions

Analysis of the design brief must be completed in order to progress to this stage. When the brief has been fully analysed, a clear understanding of the requirements of the brief and a number of design problems/questions which need to be answered through investigation, will have been established.

What should I include in this section?

There are two distinct elements to this stage of the process.

1. **Investigation:** clearly detail the investigation that has been completed. The investigation needs to display your understanding and interpretation of the acquired information as opposed to a collection of information gathered. There is limited value in reproducing material gathered from the internet, magazines books etc.
2. **Possible solutions:** using the information from your investigation, communicate a number of possible solutions to the design problem using a variety of presentation techniques.

The presentation of possible solutions must;

- convey the principle of operation of the design solution
- outline how each solution meets the requirements of the brief
- present advantages and disadvantages of each solution

Investigation:

A variety of methods of research/investigation should be accessed and utilised. This will facilitate the creation of design solutions which are:

- Unique
- Complete and comprehensive
- Capable of being manufactured in school
- Capable of being manufactured within the time constraints

Research can take two forms;

- Primary Research
- Secondary Research.

Primary Research

This entails the observation of associated objects in your immediate environment or locality. These solutions can be broken down and analysed, allowing elements of the design to be taken and modified to the specific needs of the design problem. Primary research gives unlimited first-hand

experience of possible solutions to a problem which can be referred back to again and again as required throughout the process.

“I think we are sometimes too quick to go straight to the web for inspiration or to look something up, so much so that we forget to take a look around our environment and take inspiration from that.”

James Dyson 2008

Secondary Research

This may include any or all of the areas listed below.

Libraries - Books - Magazines - Catalogues

Supply Stores - Exhibitions - Websites





Inspiration will be derived from all of the above methods of research. Keep an open mind as you work through them. Internet research is probably the most accessible method but it must be clearly stressed it is not the only one.

When conducting primary or secondary research the following should be considered.

What do I want to know? Be clear on what you want to get from your research. Each time you carry out research you should have questions that you want answered. This will add a framework to the research you complete and will help keep you focused. These questions will be developed from your analysis of the design problem.

What do I do if I do not know what direction to take next? Go back to your primary research methods. Review your analysis in order to get further direction on what you need to investigate. Ask your teacher for guidance on how to interpret your analysis and give direction towards further research paths which may be chosen.

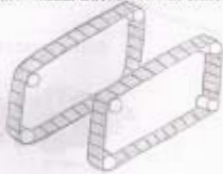
What form should my presented investigation take? Investigation is a very important part of the design process. When presenting your research you will need to condense it down and give the reader a clear picture of the research you have carried out. Using images and freehand sketches is a clever way of presenting your investigation. Images and annotations together give a distinct representation of the research undertaken. *Printed material taken directly from the internet/magazines should not be included. Students must show evidence of how they used information from their sources not what information they acquired.*

<p style="text-align: center;">One track in the middle</p>  <p>The good point of this method is that it spreads the weight of the of the snow mobile over a wider area which means it floats over the snow. The bad point of this method is because it has more of a chance of skidding. This type of rear propulsion is good for utility and special purpose snow mobiles. Some manufactures try to correct the problem of bad traction by adding spikes to the bottom of the tracks. This means they can be used in competition and recreational snowmobiles but are not as good as two tracks.</p>	<p style="text-align: center;">Back wheels with spikes</p>  <p>This method is only used in very few snow mobiles. The reason that regular vehicles can not travel in snow is because the wheels have no traction. However when the wheels are specially designed to travel in show like these ones which incorporated spikes to dig into the snow they will do better in these harsh weather conditions.</p>
<p style="text-align: center;">Two individual tracks. One at either side.</p>  <p>The bad point is it has smaller sized tracks so it sinks into the snow because the weight is spread over a smaller area. The good point of this is that since it digs into the snow it has more traction in the snow and it allows the snowmobile to make sharper turns. Therefore this method of rear propulsion would be better for a competition or a leisure snowmobile.</p>	<p style="text-align: center;">Screw propelled</p>  <p>This is a method that was used in 1926 on vehicles which travelled in the snow. The snow mobile hadnt ben invented at this time so the method was never considered for the snowmobile. The method consists of two auger like cylinders. One at each side with one turning clockwise and one turning anti clockwise. This method was used to travel on snow, mud and sand. This method would be good for any type of snow mobile because it can be as fast or slow as the manufacturer wants to make it. It also provides alot of traction because of the threads and because it spreads the weight over a wider area.</p>

Example of student investigation: Images, sketches and annotations/written may be used to demonstrate research and show how it has impacted on possible solutions.

“Encourage candidates to explore a wide variety of possible solutions before they decide on their individual final solution” (Chief Examiners Report: State Examinations Commission, 2011)

Exploring possibilities is very important as it helps to develop a clear understanding of the challenges which will be faced. It also ensures that the final solution will be well thought out and constructed, maximising the potential for its success.

Having completed the analysis and investigation of the design brief the student should now be equipped to explore a series of possible solutions to the design problem or elements thereof. If the student has difficulty developing these ideas they should revisit the analysis and investigation of the brief to develop further inspiration.

How should I present my design solutions?

At this stage students may present several complete solutions to the design problem or several solutions to each of the individual problems outlined in the analysis. It is important that the solution is accompanied with annotations and breakout sketches which indicate the finer detail of the design solution. The student must convey how each of the design considerations outlined in the analysis have been solved and to what extent each solution goes towards solving the brief. It is not for this stage to rule in or rule out a solution but rather to discuss the merits of each one presented.

The presentation of a possible solution must;

- convey the principle of operation of the design solution
- outline how the solution meets the requirements of the brief
- present the advantages and disadvantages of the solution

You may choose to complete this on a single sheet as shown below or choose to convey this information on a separate page as shown overleaf. Simple use of colour is very effective in highlighting key areas and improving the presentation of the possible solutions.

When designing this model I had the idea of a competition vehicle in mind. A competition snowmobile should combine speed and good handling. For good handling the snowmobile shouldn't spread its weight evenly like the other ones but rather slightly dig into the snow to provide good traction for the tracks and provide a good turning circle for the skis.

Pro's

Tracks are used on most snowmobiles and work well as they get a good grip on the snow.
The rack and pinion is an effective way of converting the rotary motion of the steering to the required movement of the skis.
The snow mobiles I have seen in my investigation are sleek and aerodynamic and this design reflects that.

Con's

The body design is very complicated and would take a long time to make.
The rack and pinion requires a high degree of accuracy for it to work properly.
The rubber track will need to be got the right length or cut and glued which could create problems.

This project has a complicated steering mechanism. Points A are fixed and a gear wheel turns the black track which turns part B which turns the skis at the same time.

The rear propulsion unit of this model consists of two separate tracks. This provides a smaller surface area which digs into the snow which will provide better handling.
I would use a low torque motor in this project because the project should be lightweight and faster.
The switch I would use in this project is a push to make switch because this project requires a small light switch.

Possible Solution 1

Principle of Operation:
 This design uses a central chassis which houses two axles. The axles act as supports for two rollers around which a belt is positioned. The rear axle acts as the driver. The belt is rotated by means of a motor and pulley system which is attached to the motor. In order to control the speed I will put a small pulley on the motor and a larger one on the axle, thereby reducing the speed of the axle.

Whilst the motor is located on the top of the main body at the rear, the battery and axles are located on the underside of the main body. Due to the fact that this design uses a single track, I have added some stability in front by incorporating a wide front ski system. This is supported off the main body using two struts.

A support bushing is fixed to the top of the main body through which the steering column is located. This will provide better support for the steering column when turning. As the handle bars are turned the front of the ski moves left or right allowing the driver to steer. I took this idea from a go-kart which I looked at during my investigation.

The seat is cut from a large block of plastic. This means it can be moulded to suit the driver similar to the real thing.

Advantages:

- ✓ A good strong sturdy design with all elements attached to a central chassis.
- ✓ Drive mechanism will be very effective if the right type of belt can be sourced to suit the conditions.
- ✓ The overall design should be very stable due to the low centre of gravity and the wide skis in front. This will ensure that it doesn't topple over.
- ✓ The steering mechanism is quite simple and even at this stage I would be confident that it will work quite well.
- ✓ With the central chassis, moulded seat, front ski system and single track it resembles an actual snowmobile quite well.

Disadvantages:

- ✗ The belt and pulley system could be prone to slipping due to the wet conditions.
- ✗ The moulded seat could prove problematic and cumbersome.
- ✗ A significant number of parts made from metal – it could be overweighed.
- ✗ The body shape may be oversimplified and does not take into account positioning of the driver's legs.

Criteria for selection of solution

The point is now reached where decisions are required in relation to what design ideas are going to be progressed further and what design ideas are going to be eliminated. These decisions are made based on the requirements of the brief as identified in the analysis.

Through analysis we gained a thorough understanding of the requirements of the brief. These same requirements identified direction for investigation. Possible solutions were generated on foot of this investigation. A design solution must now be chosen which best meets these criteria.

This solution may be derived from one of the possible solutions or a combination of different elements of the possible solutions. It is important to communicate the rationale for choosing one particular solution over another.

Note: If using a combination of elements from various solutions a freehand presentation must be generated to convey this new, combined design.

As part of the presentation of possible solutions the student will have;

- conveyed the principle of operation of their design solutions
- outlined how each solution met the requirements of the brief
- presented the advantages and disadvantages of each solution

It is essential that this level of interrogation of the possible solutions has been completed in order to make an informed decision

An example of a student's justification for choosing their propulsion system for their snowmobile (2011) is outlined below.

"I decided to use the chain and sprocket system from solution 2 as my chosen drive mechanism. I decided to use this method as I feel it best reflects the drive of a real snowmobile. I feel that it would provide a strong drive mechanism from the motor and it is less likely to slip, unlike the belt and pulley system in Solution 1. A larger spur gear on the axle coupled with a smaller gear on the motor will enable me to reduce the output speed. The chain and sprocket system gives greater freedom for positioning on my model, unlike the meshing gears in Solution 3."

This level of rationalisation should be employed for all requirements of the design.

Planning & Production Drawings

Planning is key to achieving success in solving any design based problem. The depth of planning undertaken throughout all stages of the project is captured in the design folio and will have a direct impact on the quality of the artefact which will be produced. Planning is an integral part of all aspects of the process of design. Therefore, evidence of planning should be presented in all elements of the process.

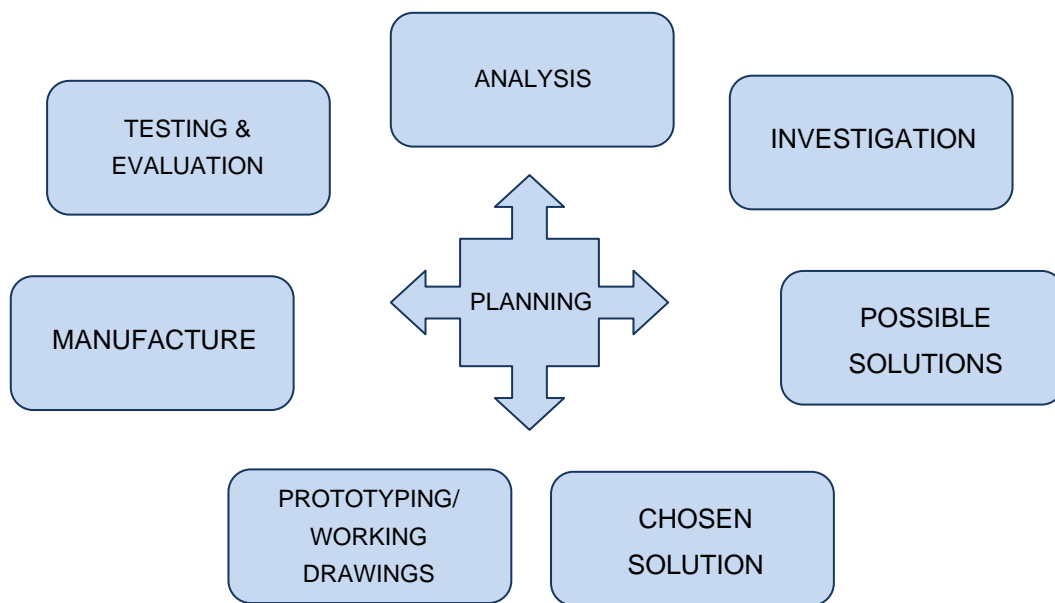

Analysis and investigation will have been considered at this stage. This element will focus on the creation of a prototype, working drawings and a work schedule.

Why create a prototype?

Students should create a prototype at this stage for a number of reasons. The process of producing a prototype model;

- Yields an understanding of shape, size, form and proportions.
- Makes the process of generating 2D drawings much easier as they will have a 3D model to work from. The prototype bridges the gap between 2D and 3D.
- Help students to plan the manufacture of their chosen solution and may identify problems that they had not envisaged.
- Affords an insight into problems that may be faced when manufacturing the chosen design.
- Offers the student the benefit of having something tangible to refer back to as they manufacture their project.

The prototype should replicate, as closely as possible, the finished project. It should endeavour to demonstrate how the final solution caters for all requirements of the brief.

The criteria for the snowmobile (Engineering – Technology Project: Design 2011) are outlined below.

The model snowmobile should;

- Have the rear propulsion unit controlled by an ON/OFF switch:
- Incorporate front skis with a steering mechanism
- Have seating capacity for the driver only

An example of a student prototype, which satisfies all of the above criteria, and the completed artefact for the Snowmobile are shown below.

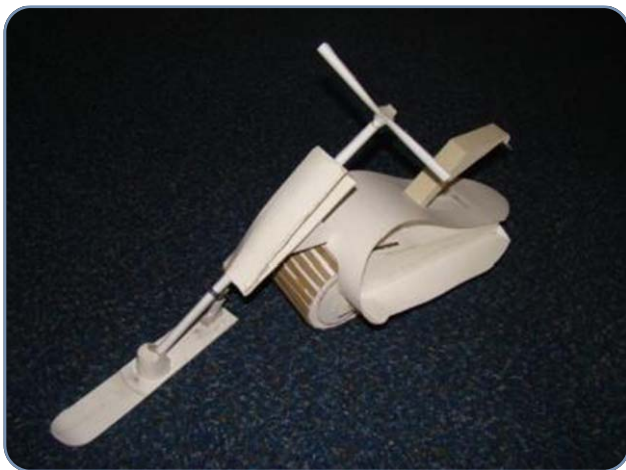

Initial prototype made from card and other materials

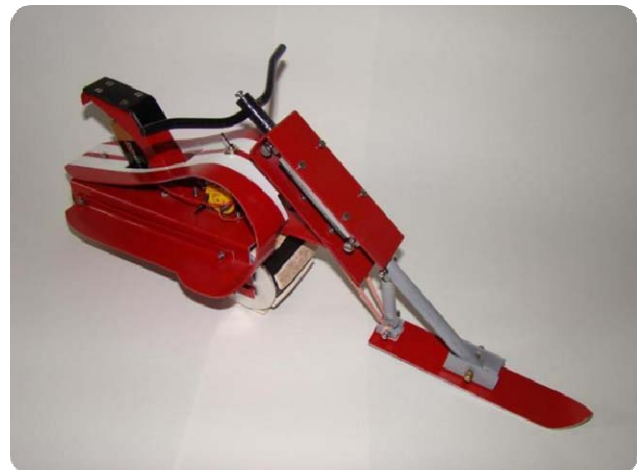

Completed Snowmobile

Working Drawings

A good prototype will lend itself to the process of producing working drawings to facilitate planning for the next stage, manufacturing. These drawings will guide the student through the manufacturing process, and will ensure more fruitful use of the time available for manufacture. Completion of the working drawings using the prototype model will help to eliminate problems which may otherwise go unnoticed and lead to parts being made and remade over and over again. Production drawings will help with the assembly of the finished project. These working drawings may be completed by hand or using SolidWorks. Students are encouraged to utilise Computer Aided Design (CAD) where possible, as indicated in the instructions to candidates' document, issued by the State Examinations Commission.

What should be included in the working drawings?

The working drawings should present all of the data required to manufacture the artefact. Some or all of the following views of the artefact may be presented;

- An assembled pictorial view.
- Orthographic views of the assembly.
- Orthographic views of each component complete with dimensions.
- An electronic circuit diagram using appropriate symbols.

Electronic components such as: motors, LEDs, batteries etc. do not need to be included in the working drawings. However, their shape and proportions will influence the design of individual parts.

Assembled Pictorial View.

An assembled pictorial view will afford the reader an overall view of the proportions of the artefact. SolidWorks affords the student the ability to extract a number of views of the assembly to give a detailed understanding of how the model is assembled. These views can be presented on a sheet on their own, or included with orthographic views.

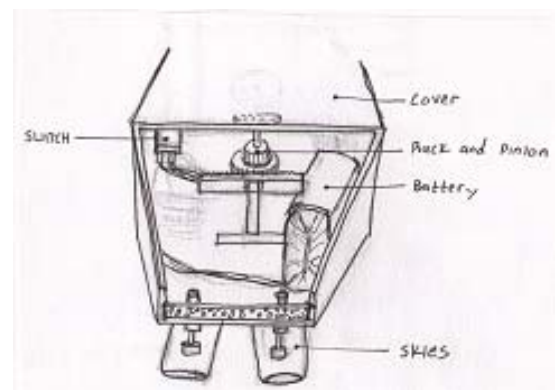
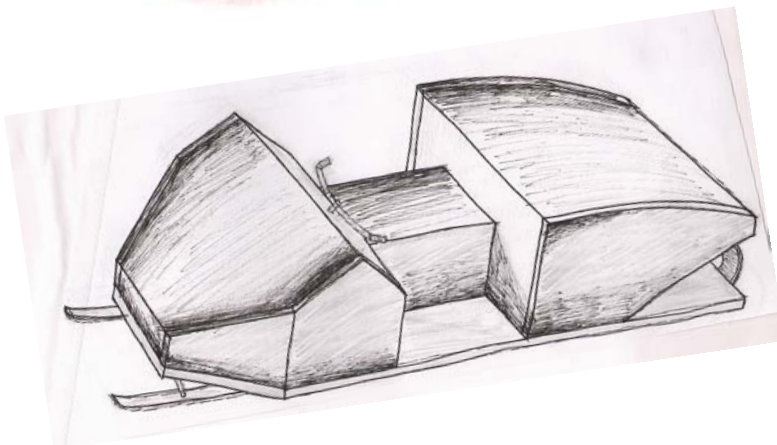
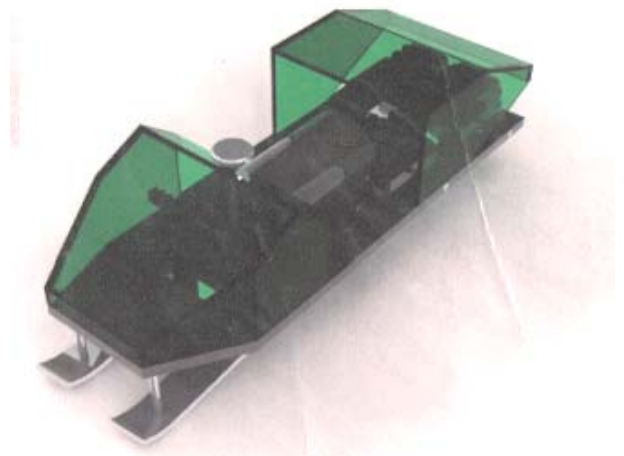
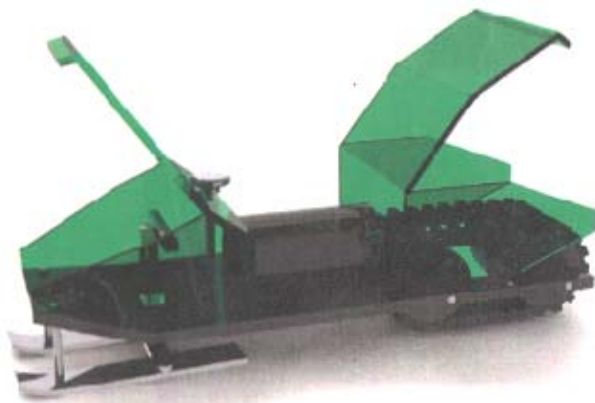

Orthographic view: (Including Dimensions)

These working drawings represent planning which will enable the artefact to be manufactured successfully in the time available. For that reason, orthographic views must be presented for each component part accompanied with balloon referencing indicating part numbers. Appropriate views of each component are chosen to convey all of the necessary information. The advantage of modelling the artefact in SolidWorks is that orthographic views may be extracted for each component. Should you have to revisit the design of a component at a future stage these orthographic views will update accordingly avoiding unnecessary redrafting.

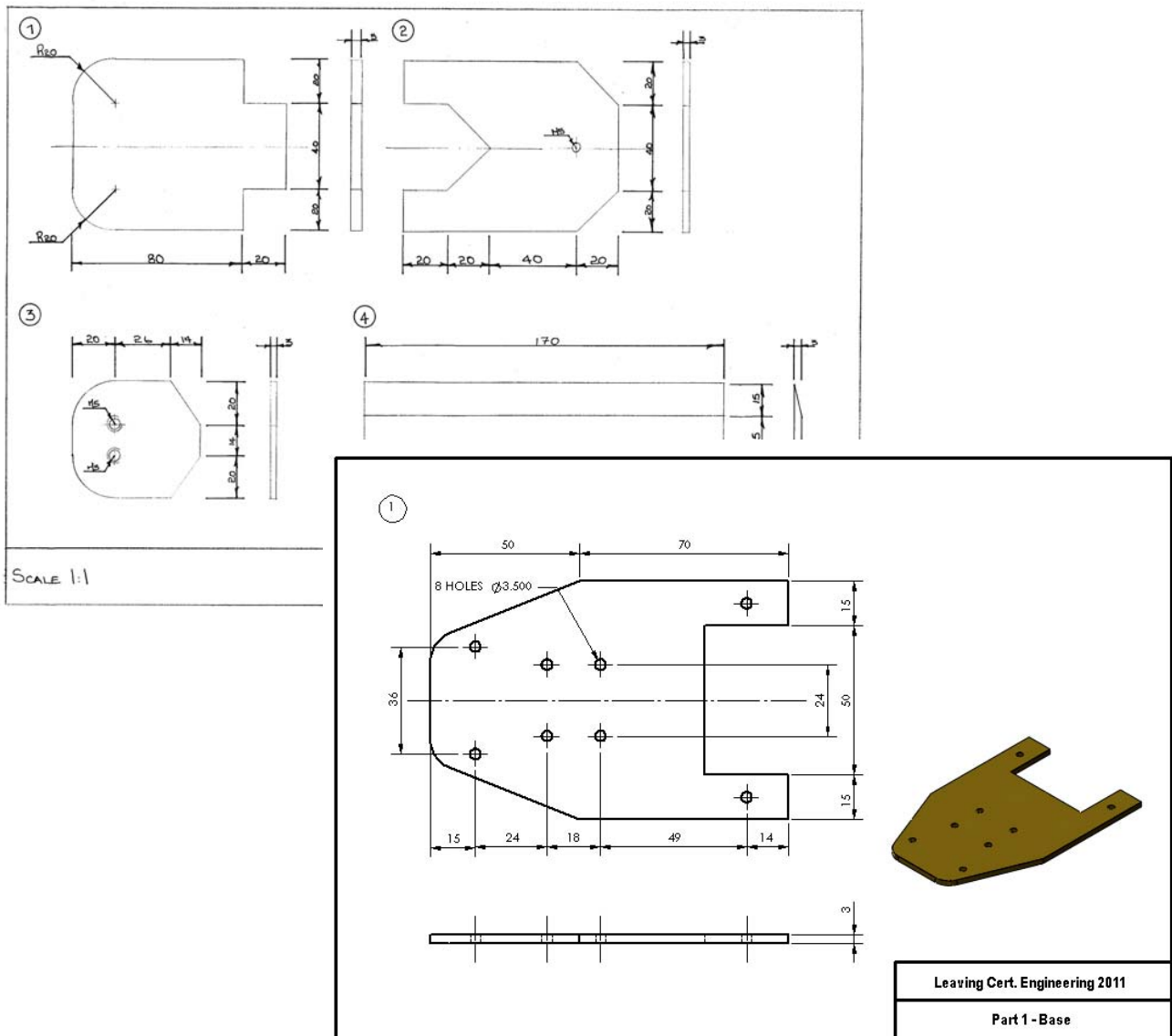

Parts List

In order to commence work on the manufacture of the artefact a parts list must be produced. This list should contain the following information;

Part Number, Part Name, Material, Dimensions and Quantity

The part is identified by balloon referencing in the assembled pictorial view and individual part numbers accompanying the orthographic views. A sample of a student's completed parts list is shown below. The balloon referencing of the assembly helps to clearly identify each part.

Part No.	Name	Material	Dimensions	Quantity
1	Bonnet	Aluminium	188 x 130 x 1	1
2	Rear Housing	Aluminium	155 x 150 x 1	1
3	Steering Bars	Aluminium	130 x 95 x 1	1
4	Ski	Aluminium	145 x 20 x 3	2
5	Seat Platform	Acrylic	105 x 72 x 3	1
6	Base	Acrylic	275 x 130 x 3	1
7	Seat	Nylon	Dia. 40 x 75	1
8	Front Ski Support	Aluminium	Dia. 12 x 33	2
9	Back Ski Support	Aluminium	Dia. 12 x 27	2
10	Steering Column	Aluminium	Dia. 12 x 53	1
11	Side Auger Casing	Acrylic	70 x 70 x 2	2
12	Top Auger Casing	Acrylic	105 x 70 x 2	2

Electronic Circuit Diagram

A graphical representation of the electronic circuit diagram designed to facilitate the operation of the artefact must be presented. A candidate's circuit diagram for the Snowmobile (Engineering – Technology Project: Design 2011) is presented below.

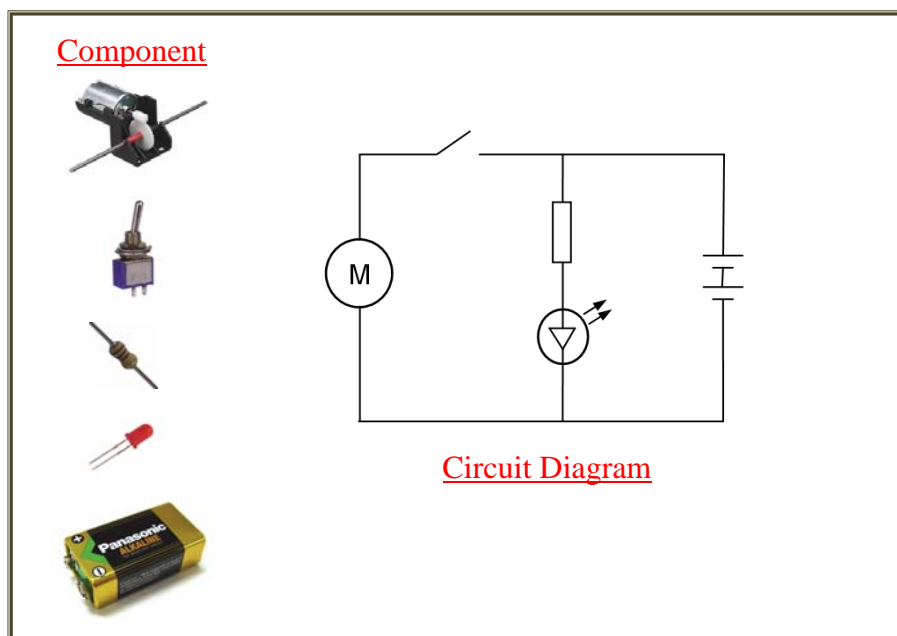

Manufacture

All of the analysis, investigation and planning culminates in this element of the process, the manufacture of the artefact. It is therefore vital that a thorough analysis has been completed, and a comprehensive investigation has resulted in some well thought out design solutions. A clear rationale for selecting the chosen solution must have been outlined as well as a detailed work plan. Whilst it is accepted that some problems will be encountered in the manufacture of the best thought out design; working through the stages as outlined in this document will reduce the occurrences of these. On the other hand, starting manufacture without a comprehensive plan in place will result in false starts, redesigning over and over again as you go, wasted material and as a consequence a less than successful outcome. *Failing to plan is planning to fail.*

Before manufacturing is undertaken it is vital that a number of design considerations are taken into account. These considerations include:

- Mechanisms Employed
- Material Choice
- Manufacturing Processes
- Joining Processes
- Electronic Wiring
- Finishing Techniques

Consideration has already been given to some of these in the previous stages of this process.

Mechanisms Employed

When the brief is analysed, the requirements are identified including the necessary movements of parts relative to one another. For example, steering was a requirement of the Lunar Roving Vehicle (Engineering – Technology Project: Design, 2012). Analysis of this requirement identified a need for a mechanism which would convert rotary motion (Steering) to linear motion (turning of the wheels). This demands that the student investigate a number of possible mechanisms which would solve this problem. Similar analysis and investigation must be completed for all other requirements.

A useful resource for Structures and Mechanisms, as well as others, is available through the T4 website at the link below.

http://www.t4.ie/Technology_Resources_Core_Structures.html

Material Choice

It is important that suitable materials are chosen for each component part of the project. The artefact produced is a model and as such should use materials which allow it to be lightweight, portable, well finished and manufactured in school using the bench and machine tools available in the classroom. The material used does not need to be the same as the materials used in real world examples of the project.

The engineering project brief includes specifications which will impact on material choice. The brief usually states that “*all main operating features are clearly visible without dismantling*”. This may be provided for through prudent design and positioning of component parts or the student may consider the use of clear or tinted acrylic or a mesh for parts of the project which restrict view.

The following should be considered in deciding what materials to use:

- Is the material available in a light gauge? This will make it easier to work with the material and will ensure that the finished project is lightweight.
- Does it have the desired properties? Can it be bent into shape? Is it strong enough to hold the weight of the project? Can it be cut, drilled and filed easily? Can it be finished to a suitable level? What joining techniques can be employed using particular materials?

These questions need to be answered before a material is selected.

Manufacturing Processes

The project is an opportunity for the student to display the practical skills they have developed through their study of Engineering at Second Level. The student should use the tools and manufacturing processes they have access to and are most comfortable with. Students should display a wide range of bench manufacturing techniques including marking out, sawing, bending, tapping, filing and polishing. Along with these, they should also use a wide variety of machine tool processes including drilling, lathe work and bending to complete the manufacture of their project.

It is important that the student selects the most appropriate processes when manufacturing each part of the project. The final assembly of the project will also have a bearing on what manufacturing processes are used e.g. if the project is to be fixed together with screws then the student will need to drill and tap a series of holes to cater for assembly.

Joining processes

Joining methods should be carefully considered as part of the planning of the completed solution. It is vital that the correct joining methods are chosen for the various elements of the artefact. The project should be joined in a manner that allows for access should it be required. If a temporary method of joining is required screws, nuts and bolts could be used. Permanent methods of joining could include, soldering, brazing, welding or adhesives. Permanent methods of joining should only be employed where disassembly is not required.

Adhesives can be a quick solution but not always the most appropriate. Adhesives should be used appropriately and sparingly. Choosing the incorrect adhesives can result in a poor quality adhesion and damage to the materials e.g. superglue burns the surface of acrylic and presentation of the artefact is diminished as a result.

Electronic Wiring

The incorporation of the wiring for the project should be considered from the outset of production. It is crucial, from presentation and safety view points, that all wiring is neat and tidy. Heat shrink is a useful material for strengthening soldered joints and insulating.

The wiring should be concealed where possible and holes may need to be drilled in the artefact to cater for routing of the wires. Battery holders, if required, should be integrated into the design solution. Some of these aspects of the design and manufacture of the artefact have been overlooked in the past and this has been noted in the Chief Examiners Report: *“At both Higher and Ordinary levels, some candidates failed to pay adequate attention to safe and neat wiring in construction of basic electronic circuits. This part of the design appeared not to be taken seriously and resulted in poor placement or housing of the electronic circuit/components, battery, loose wiring and poor soldering.”*

Students must take the electronic wiring into consideration when planning the design and manufacture of the project.

Finishing

Finish and presentation of the project is vital to successfully completing the project. The finish applied to the project will depend on the materials used. *“High quality finishes may significantly improve the efficiency in movement, the potential for accurate assembly and the aesthetic appearance of the component as well as contributing to the overall presentation of the completed artefact.”* (Chief Examiners Report: State Examinations Commission, 2011) It is crucial that time is afforded to producing a quality finish on each of the component parts.

In general all parts should;

- be free of sharp corners
- be filed smooth with all burrs removed
- be cleaned and prepared for polishing
- be polished to a high shine

Metals may be given a protective coating of paint, or clear lacquer to avoid subsequent tarnishing. Screws should be cut to an appropriate length. All wiring should be neat and tidy.

Testing & Evaluation

Testing

Having completed manufacture, assembly and wiring the next stage is to test the artefact to see how well it performs. At this point it is necessary to revisit the requirements, as identified in the analysis, and test the operation of the artefact under these headings.

A clear outline of the tests carried out as well as factual information resulting from the tests must be presented. The tests must be designed such that they can identify to what extent the artefact satisfies the design requirements. Tests may show up shortcomings in the design of the artefact and this may require some redesigning and manufacture to overcome these problems.

An example of a student's outline of one of the tests carried out for the lifting mechanism for the Gantry Crane (Engineering – Technology Project: Design 2010) is detailed below.

“With just the weight of the hook, I connected a battery to the circuit and flicked the switch for the lifting device. The motor turned and the pulley attempted to wind the fishing line around itself. I found that the weight of the hook was not sufficient to provide enough tension to coil the fishing line around the pulley. I borrowed some known weights from my physics teacher. I ran the test again with a 5 gram weight attached. This time the weight ensured that sufficient tension was placed on the line and it wound around the pulley and lifted successfully. I repeated the test using 10, 15 and 20 gram weights and it lifted these successfully also. The hook was made from aluminium which is light weight. I remade the hook from steel and added some lead pellets to increase the tension on the fishing line. I repeated the test with the newly designed hook and discovered that it worked perfectly this time”

Similar tests should be performed and detailed for the various other requirements of the project.

Evaluation

Evaluation affords the opportunity to reflect on the completed project. In carrying out the evaluation both the process of design and manufacture of the artefact, the completed artefact and the test results must be reviewed. Critical appraisal, as well as possible changes to future design, is an essential component of a thorough evaluation.

The following points may be used to guide a complete evaluation:

- The extent to which the model satisfies the brief based on the tests performed
- Functionality of the model
- Choice of materials and finishes
- Manufacturing processes employed
- Suitability of assembly techniques
- Suitability of component parts and their desired functions
- Safety considerations
- Quality of the work and presentation of the model

An example of a student's evaluation of the steering mechanism of the snowmobile (Engineering – Technology Project: Design 2011) is detailed below.

“The steering mechanism works quite well as detailed in the results of the steering tests carried out. Having the steering column orientated vertically meant that the construction of the steering mechanism, using the rack and pinion, was made much more straightforward. However, the positioning of the handlebars to the driver is awkward and would require that the driver is leaning forward over the bars in order to steer the snowmobile. If I was to remake the model again I would position the steering column at an angle, which would make the positioning of the rack and pinion much more complicated, but it would guarantee that the driver would be more comfortably positioned and mimic the real thing more closely.”

A similar level of evaluation should be presented for the various other requirements of the project.

Appendices

Appendices may be included to present other relevant information e.g. photographs of the completed artefact.



A guide to the Engineering – Technology Project: Design

Leaving Certificate Engineering affords students the opportunity to develop skills in creativity, problem solving, innovation, research, enterprise, design, manufacture and reflection. ICT is an integral part of this learning environment.

The student project provides the medium through which some or all of these skills may be expressed and assessed.

The purpose of this document is to offer guidance to both teachers and students on possible approaches to successfully completing the Engineering – Technology Project: Design.



Technology Subjects Support Service Galway Education Centre, Cluain Mhuire, Wellpark, Galway

Seirbhís Tacaíochta um Ábhair Teicneolaíochta Ionad Oideachais na Gaillimhe, Cluain Mhuire, Wellpark, Gaillimh

Tel/Fón: 091 745 650 | Fax/Facs: 091 745 618 | Email/R-phost: admin@t4.ie www.t4.ie